

Ice cream machine manuel



Please read this manual carefully before installation and use

Please keep this instruction manual properly

1. Introduction

The commercial ice cream machine produced by our company adopts advanced digital computer control system, high-quality famous brand compressor and advanced production technology, which is easy to operate, safe and reliable. The ice cream machine has a high puffing rate and high output, and the ice cream machine made has a smooth and tender taste. Widely used in cold drink shops, fast food chain restaurants, western restaurants, stores and other food service industries.

Product structure

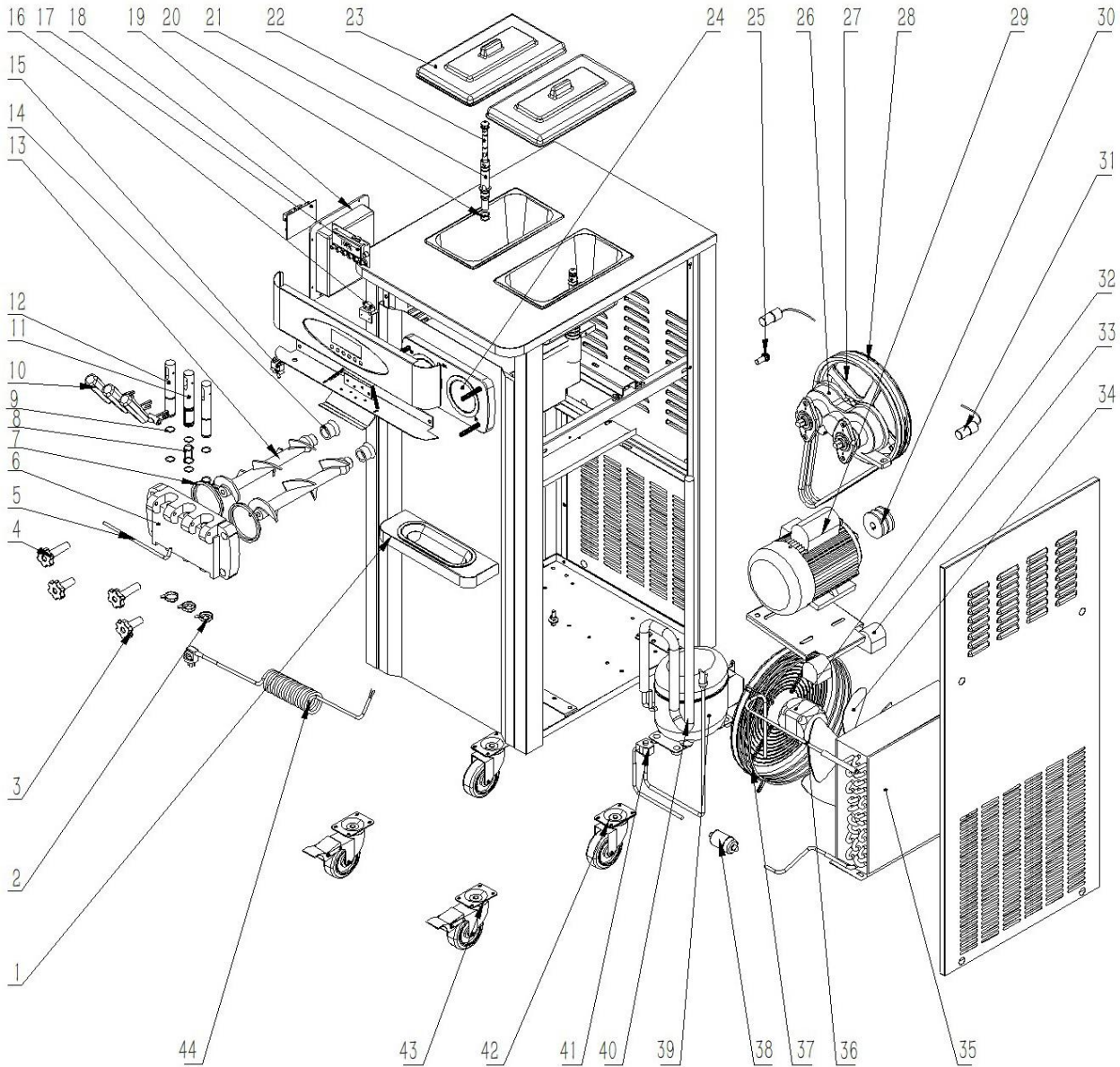

1	Tray	12	Valve	23	Cover	34	Fan blade
2	Cap	13	Beater	24	Cylinder	35	Condenser
3	Short bolt	14	Horn set	25	Speed sensing probe	36	Exhaust pipe
4	Long bolt	15	Toggle switch	26	Reducer	37	Fan guard
5	Pin	16	Micro switch	27	Big pulley	38	Filter
6	Discharger	17	Display	28	Belt	39	Compressor
7	D-ring	18	Board	29	Motor	40	return air tube
8	H-ring	19	Junction Box	30	Small pulley	41	Solenoid valve
9	O-ring	20	O-ring	31	Air pump	42	Mecanum wheel
10	Handle	21	Pump outer tube	32	Fan	43	Wheels with brake
11	Middle vlave	22	Pump inner tube	33	Motor shock absorber	44	Power supply cord

1. This appliance is not intended for use by persons (including children) with reduced physical, sensory or mental capabilities, or lack of experience and knowledge, unless they have been given supervision or instruction concerning use of the appliance by a person responsible for their safety. Children should be supervised to ensure that they do not play with the appliance.
2. If the supply cord is damaged, it must be replaced by the manufacturer, its service agent or similarly qualified persons in order to avoid a hazard.
3. The installation instructions shall state the maximum and minimum ambient temperatures for correct operation.
4. For appliances that are not at least IPX5, the instructions shall state that the appliance is not suitable for installation in an area where a water jet could be used.
5. The installation instructions shall state the maximum tilt of the appliance for safe operation.
6. The instructions for maintenance shall include instructions for descaling, cleaning and give details for the flushing and removal of any residual cleaners, sterilizers or descalers from the appliance, if applicable.
7. If the appliance is not at least IPX5, the instructions for maintenance shall state that the appliance must not be cleaned by a water jet.
8. The instructions for maintenance shall list any accessories that may be used with the appliance.
9. The instructions for maintenance shall state the maximum and minimum ambient temperatures for correct operation.
10. For appliances using water, the instructions for maintenance shall give details concerning the prevention of freezing or how to ensure safe operation if freezing occurs.

2. Installation

- The ambient temperature of the ice cream machine is 10~38°C and the humidity is 55~85%.
- The ice cream machine should be placed in a place out of sunlight and away from heat sources.
- The ice cream machine should be placed on a stable floor, and the desktop ice cream machine should be placed on a firm surface.
- There must be good ventilation around the ice cream machine. There should be a space more than 150mm on both sides, 200mm on the back, and 300mm on the top.
- Do not place the ice cream machine in a humid or wet environment.
- After the vertical ice cream machine is placed in place, the front two universal wheels should be locked in time to prevent the machine from moving during operation.

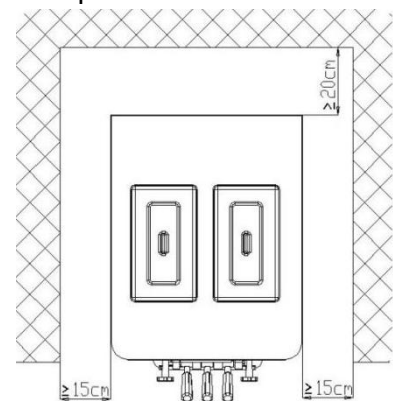

A. Power connection

- Power supply for ice cream machine: 220V/50Hz, voltage fluctuation 198~242V
- The power socket connected to the ice cream machine should meet the standard requirements, and the socket should have a good grounding.
- Use appropriate power cords according to different models. For machines 25 L/hour and below, copper core wires of not less than 2.5mm² should be used core wire.
- The machine should use an independent control switch. The tripping current of the switch of the machine 25 L/hour and below is 25A, and the tripping current of the switch of the machine 25 L/hour or more is 32A.

B. Unboxing and Inspection of the New Machine

- 1) Disassemble the packing tape and wooden board that fasten the carton; remove the carton and foam board and take out the packaging bag to check whether the appearance of the machine is damaged; if there is any damage, please contact the supplier or transportation company. (Note: During the process of moving the machine, the machine must not be inclined

more than 45°)

2) Check the spare parts of the machine. There are handles and sealing rings for wearing parts in the spare parts box, please keep them properly.

3) Disassemble the left side panel of the machine, check whether the internal motor, belt, compressor and other components are loose due to transportation, and contact the supplier in time for any abnormality.



Spare parts box

3. Installation of parts

Beater

Install the beater according to the picture, pay attention to apply Vaseline to the horn set of the beater.

The beater should be rotated and pushed in slightly left and right, and it should be level with the cylinder after it is installed in place.

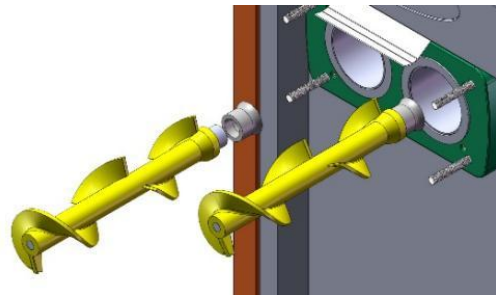

Dischager

Install the discharger of the ice cream machine according to the picture, and pay attention to apply Vaseline to the sealing rings of the valves.

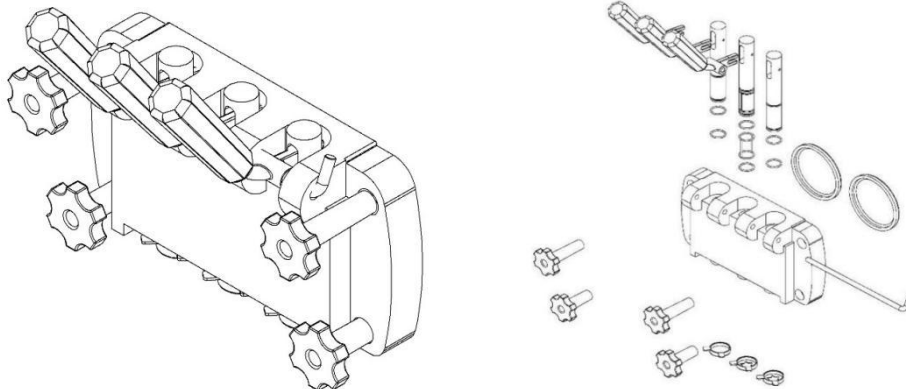

Tray

Put the tray on the two fixing nuts in the middle of the machine to carry the residual material left when making ice cream. Please do not put buckets, washbasins, etc.

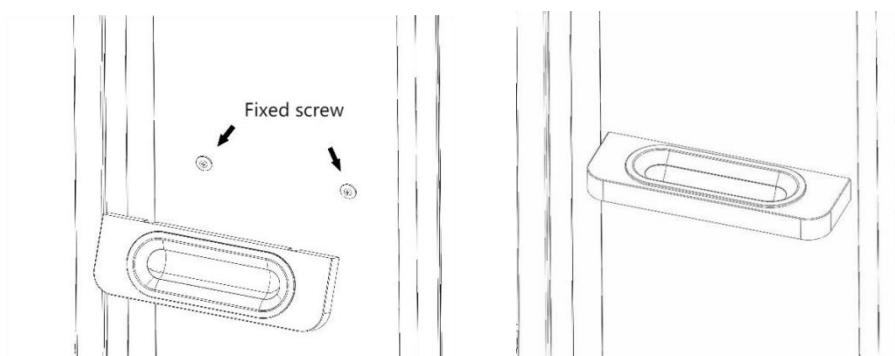

Puffing tube installation

Install the puffing tube in the hopper of the ice cream machine, and pay attention to the O-ring at the front of the puffing tube should be coated with Vaseline.

By rotating the inner tube of the puffing tube, the amount of air entering the ice cream slurry in the cylinder of the ice cream machine can be adjusted to adjust the puffing rate of the finished ice cream, so that it can get a good taste.

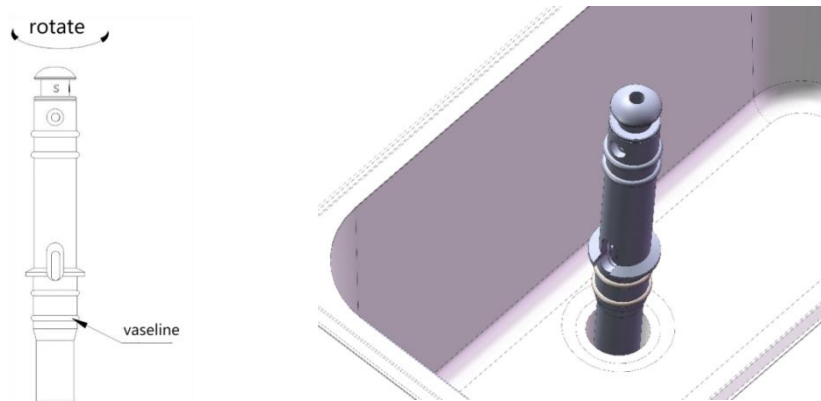

After all parts are installed, pour about 2L of clean water into the hopper, check whether the machine leaks, and then pull down the handle to release the water.

If machine has been connected to the power supply, you can press the clean button to check the operation of the machine motor.

ATTENTION

- When the empty cylinder has beater, not allow to freeze. Freeze without beater is not allowed to exceed 3 minutes;
- Not allow to freeze when cylinder has water.

How to operate

The display above the panel is as shown in the figure. Different Settings can display different parameters. You can see the following operation instructions. .

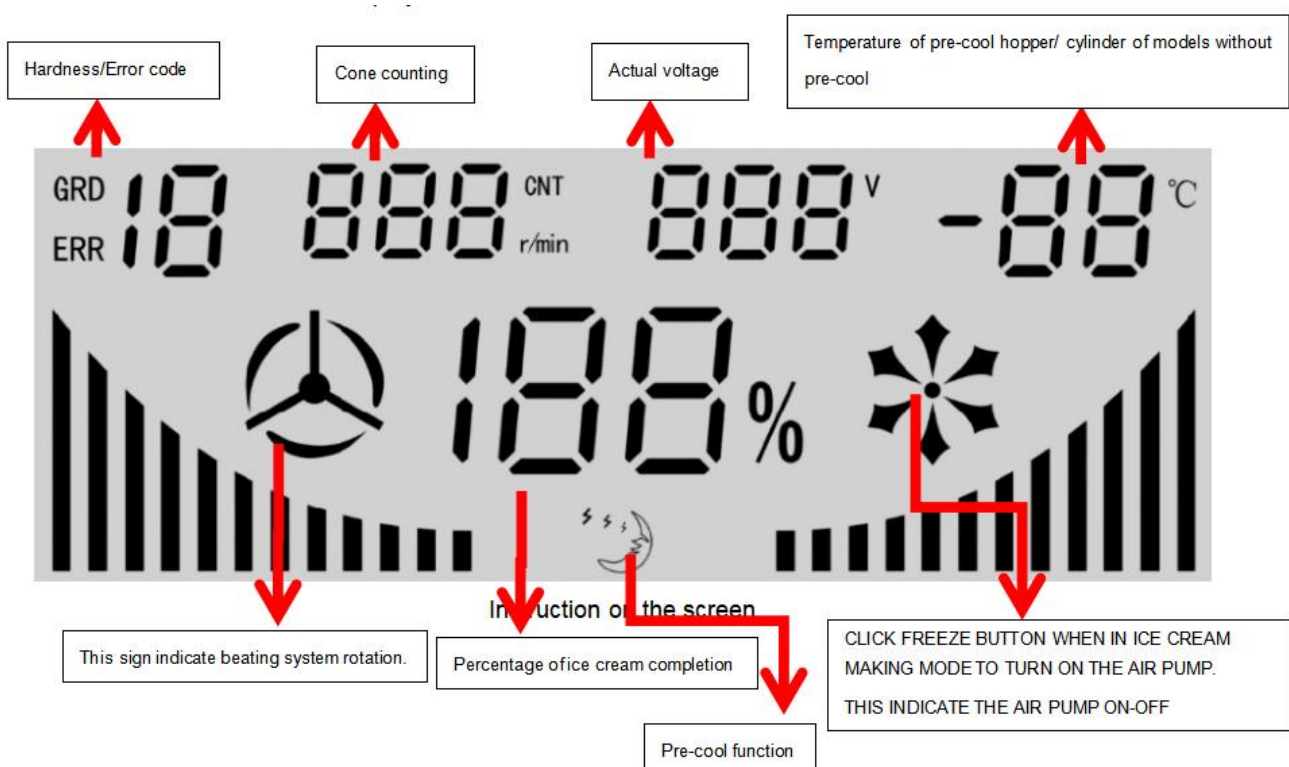

Operation



After the machine is plugged in, the machine goes into standby mode when the power switch is turned on.

- **Standby mode:** The mode in which no button is pressed after power on. The screen lights up while the refrigeration and agitation mode do not rotate.
- **Wash mode:** Press the wash button, the agitation indicator lights up, and start the agitation motor to enter the wash mode. Press the stop button to exit the wash mode and return to standby mode.
- **Freeze mode:** Press the freeze button, the refrigeration icon lights up, and enter cooling mode. After entering the cooling mode, the stirring motor will start immediately. After 5 seconds, the main compressor will start. With the progress of the cooling process, the hardness of the ice cream material will reach the set value, and the cooling will stop. In this case, the standby icon flashes and the cooling icon closes. If no material is discharged during the set automatic restart time, the system will automatically repeat the above cooling process. After the cooling is complete, if the discharge rod is pressed down, the cooling mode restarts. In the cooling mode, press the stop button to exit the cooling mode and return to the standby mode.
- **Pre-cooling and preservation (also known as overnight function)** If have pre-cooling: In standby mode, press the Set/pre-cooling button to enable or disable the pre-cooling and preservation functions. Press the set button, the fresh-keeping pattern in the lower middle position of the display screen flashes, and the pre-cooling is automatically turned on.
- **Air pump and defrost**
Press the freeze button to enter the cooling mode and automatically turn on the air pump. After starting cooling, press the key repeatedly to manually shut down the air pump or start the air pump again. When the air pump is enabled, the center of the snowflake icon column is lit, otherwise it is extinguished.
If the defrost function is enabled, hold down the freeze button in standby mode to enable the defrost function.
- **Gear adjustment**
In standby, cleaning, or freeze mode, you can adjust the ice cream's hardness gear: long press the hard or soft button, wait for the gear value to flash, release the button, and then increase the gear by pressing the hard button alone or decrease the gear by pressing the soft button alone.
(The parameters are set when leaving the factory, the general situation is not adjusted. If you have any questions, please contact the factory staff)

Parameter setting

- Machine parameter setting is divided into factory parameters and user parameters. User parameter setting can be entered by long pressing the set key (for 5 seconds). After entering the setting screen, press the set key alone to switch user parameters of different group numbers, and use hard or soft keys to modify parameters.
- Factory parameter must be accessed by holding down both the set and stop buttons. After entering the setting screen, press the setting key to switch the parameter group number. The user parameter is still

displayed first, and the factory parameter is displayed only after the last user parameter is switched. The adjustment method is the same as user parameters. Detailed parameter table is shown in Table 1.

(Parameters are set when leaving the factory, generally do not need to adjust. If you have any questions, please contact the factory staff)

4. Operation

1) Wash

- Plug the machine into a power supply and turn on the power switch at the bottom left corner of the display.
- Fill up the hopper with drinking water (you can add food disinfectant to clean the machine for the first time, which can sterilize) and press the wash button to work for about two minutes, directly press the handle to discharge the water under the running state of the machine cleaning, clean the machine 2-3 times, until the water from the discharger is clean. .
- You can use hot water to clean, but don't higher than 60 ° C.
- The machine should be washed immediately after the daily using the machine.

2) Ice cream formula

- Ice cream is usually made using ice cream powder and water. Please mix the ice cream powder in strict accordance with the proportion on the packaging bag (generally 1 kg powder and 2.5-3 kg pure water). After adding water, please mix the ice cream powder with tableware and mix it evenly. Let the water and ice cream powder fully dilute and dissolve, and let it stand for 30 minutes.
- Note: Add water exactly in the same proportion as the formula, mixing and standing are important, which directly affect the capacity and taste of the ice cream.
- The temperature of the ice cream shouldn't exceed 40°C, as excessive temperatures degrade the machine's performance and can even cause it to malfunction.

3) Make ice cream

- Make sure to drain the water thoroughly, pour the mixture into the hopper, keeping the ingredients from clumping together.
- Ice cream mixture should be added to 2/3 or above the height of the hopper, but no more than the top mouth of the tube, or 20mm below the top surface of the dish. (according to the lowest value of both)
- When the machine is running, the ice cream mixture in the hopper cannot lower than the outlet position.
- Press the wash button (the machine mix the ice cream again to make it more even.) After about 2 minutes, press the freeze button to start working. (Note: In any case, the two hoppers should be kept full, and the minimum can not be lower than the position, otherwise it will get into the state of lack of material, resulting in increased noise and machine damage)
- During the making process, the screen shows the cooling state, and generally when 80% or more of the ice cream is formed, the ice cream can be dispense.
- Cooling stops when reaches 100%, and then the stirring motor stops after delay and automatically enters standby mode, at this point if you pull the handle, the machine automatically starts stirring and cooling. If there is no beating within 5 Minutes (time can be adjusted), it will automatically re-cooling and stop again when the hardness reaches 100% to ensure that the ice cream in the machine is in the shape of the state.
- To dispense the ice cream: Take a cone or cup, place it at the outlet under the discharge valve, press down the handle, and rotate the cone with your other hand, pushing the ice cream back onto the handle.

4) Pre-cooling and preservation (also known as overnight function)

- After the pre-cooling function is turned on, the machine cool the ice cream mixture in the hopper, keeping the temperature of the ice cream mixture in the hopper at 0~10°C, enabling the mixture to be stored for a short time.
- Preservation function is to evaporate the mixture in the cylinder, in a long time standby mode, timed refrigeration, so that it is kept at low temperature. In standby mode, press the set button to enter the

pre-cooling / preservation mode.

- Because ice cream is made from dairy products, it's rich in fat, protein, and sugar, which can easily spoil if kept improperly. Therefore, users should follow the relevant food hygiene requirements.

5. Maintenance

1) Wash

- You have to clean the ice cream machines every day, to ensure the health of us and improve the life of the machine parts.
- For an ice cream machine with insulation, you can set the machine to pre-cooling at night, keeping the ice cream in the hopper below 10°C, and use it with new mixture the next day, eliminating the need for daily cleaning.
 - a) The machine must be cleaned in compliance with the requirements of health regulations, if so required.
 - b) If there is no clear requirement, the machine must be fully cleaned every 3 days, and the discharger should be taken off and cleaned.
- Using warm water when cleaning, can add neutral edible washing liquid, while using a soft towel to wipe the material plate, evaporation cylinder wall, clean the material head with a small brush.○

Cleaning steps

- ① Press the wash button to dispense all the mixture in the cylinder, and press the stop key.
 - ② Add disinfectant with warm water and pour it into the cylinder.
 - ③ Press the wash button and stir for about five minutes to dispense the cleaning solution.
 - ④ Clean with water 3 to 5 times, stop the machine.
 - ⑤ Turn off the power supply and remove and wash each part.
- If you stop using for a long time, you must dismantle and clean each part and reinstall it in the following steps:
 - ① Unscrew the four screws on the side of the discharger and remove the discharger;
 - ② Pull out the handle fixing pin, handle, valve and sealing rings from the discharger in turn;
 - ③ Pull out the beater from the cylinder and remove the sealing rings;
 - ④ Clean and disinfect all the parts removed, if damaged, please replace them in time;
 - ⑤ Install the parts according to the opposite steps of disassembly.Note: the sealing ring in the middle of the valve is H ring, and the two sides are O ring, do not install wrong.
 - Keep the appearance of the fuselage clean and dry, wipe the fuselage with a wet towel to remove stains, and do not directly rinse the operating panel or internal parts with water, in order to avoid electrical failure.

2) Clean the condenser

Using for a period of time, the condenser will be covered with dust, which will affect the heat dissipation, and the cooling effect will be worse (for the same time, the ice cream will become soft). Please be sure to clean it once every three months (if the environment is poor, please clean it once a month). Turn off the power supply before cleaning, and be careful not to damage the fins of the condenser. (Recommend Professional cleaning)

3) Belt adjustment

After the machine is used for a long time, the driving belt of the stirring system may be elongated, which will affect the normal operation of the machine, and it needs to be adjusted. Before adjusting the belt, the machine must stop, turn off the power, adjust the adjusting nut of the stirring motor with a wrench, and adjust the belt to the appropriate tightness. When the belt is too long, it needs to be replaced. (It is recommended to be adjusted and replaced by professionals)

6. Error & Solution

When errors occur, the system will shut down all outputs and display error code, meanwhile the alarm will keep beeping. Please refer to the below table for code information.

code	problem	cause	solution	remark
01	Voltage too low	Voltage too low	Check the power. If necessary, install a voltage stabilizer.	
02	Voltage too high	Voltage too high	Check the power. If necessary, install a voltage stabilizer.	
03	Speed sensor abnormal	1.Sensor not well installed 2. Magnet misplaced 3. Sensor malfunction	1.Install the sensor well 2.Adjust the position of magnet. 3.Replace with a new sensor.	
04	Belt Slip	1.Belt tightness inappropriate 2.Blender motor malfunction	1. Adjust tightness 2.Check blender motor.	
05	Weak refrigeration	Refrigeration system malfunction	Check the system	Some models don't have temperature checking function
06	Cylinder frozen	1.Mixture contains too much water. 2.Turn on when no material	1.Please make mixture according to the right proportion. 2.DO NOT turn to freeze mode when no mixture inside.	Some models don't have temperature checking function
08	Left cylinder lack of mixture.	To protect the cylinder	Pour in mixture.	Some machine lack of this function.
09	Right cylinder lack of mixture	To protect the cylinder	Pour in mixture.	Some machine lack of this function.
10	Running overtime	1.Hardness set too high. 2.The overtime value is set too short. 3.Refrigeration system malfunction.	1.Adjust to the appropriate gear. 2.Adjust the overtime value. 3.Check refrigeration system	
11	High pressure protection	Compressor pressure too high	Check refrigeration system	
	No display while machine turned on	1.Out of power, socket not well plugged. 2.Stabilizer not well connected, or display not well connected to the motherboard. 3.Fuse malfunction 4.PCB malfunction	1.Check if power supply is normal. 2.Reconnect wires. 3.Solve the abnormality and replace with the same specification of fuse 4.Check PCB	
	Display not clearly	1.Display and motherboard not well connected. 2.PCB malfunction	1.Reconnect display to the motherboard well 2.Check PCB	

- If you need to set parameters, refer to the code table. Parameters starting with P are user parameters, while parameters starting with F are factory parameters, which are not recommended to be set by the user.

User parameters

Code	Parameter Type	Parameter Definition	Marks
P00	User	Time interval of auto freeze restarting	Interval can be set between 5-30 minutes.
P01	User	Pre-cool temperature	Range from 0-20 °C , if no pre-cooling function, this code will not show
P02	User	Preservation interval time	Range from 30 to 120 minutes, If no preservation function, this code will not show
P03	User	Reset the record of ice cream	Long press "HARD" or "SOFT" to reset the record
P04	User	Air pump strength	Range from 1-5
P05	User	Air pump start delay time	Range from 10-300 seconds, default 240 seconds, this code will show only when the air pump works under delayed start mode
P06	User	Enable automatic start of air pump	ON: turn on the air pump automatically when starting refrigeration OFF: The air pump is not turned on automatically when starting refrigeration. The user needs to press "FREEZE" again to start it.
P07	User	Air pump power gear	Range from 1-4

Factory parameters (not recommended to be set by the user)

Code	Parameter Type	Parameter Definition	Marks
FO0	Factory	The elapsed time of refrigeration	Range from 30-60 minutes
FO1	Factory	Factor of hardness correction	Range from 1-10, the higher the harder. Factory default is 1. Improper adjustment can result in belt slipping or can not stop automatically.
F02	Factory	Value of low voltage protection	Range from 90V—220V
F03	Factory	Pre-cooling mode	0:No precooling 1:Single compressor pre-cooling 2:Double compressor pre-cooling 3:Double compressor pre-cooling with cylinder preservation function (overnight function)
F04	Factory	Rotation speed detection	If the speed of the machine has been identified, the speed value will be displayed. If the speed is not

			identified or the speed identified is cleared, "---" will be displayed. If the speed identified needs to be cleared, press and hold the add and subtract keys for 5 seconds at the same time until "--" is displayed.
F05	Factory	Washing time setting	0: No remind (default) 1-60min: Cleaning is automatically turned off after the set time. The unit of time is minute.
F06	Factory	Automatic record of pre-cool and preservation	ON: Automatically turn on and off the pre-cooling function as last time. OFF: No automatic function

※ If the motor or speed-related mechanical parts are replaced, please be sure to perform automatic speed identification once: enter F04 menu, delete the existing value. Then run wash mode for at least 10 seconds, the detection will be automatically completed.

※ Must be when no ice cream material in the cylinder, can operate Speed identification!

7、Wiring Diagrams (The mechanical and electrical circuits of ice cream with different function configurations are different)

1: Ordinary type

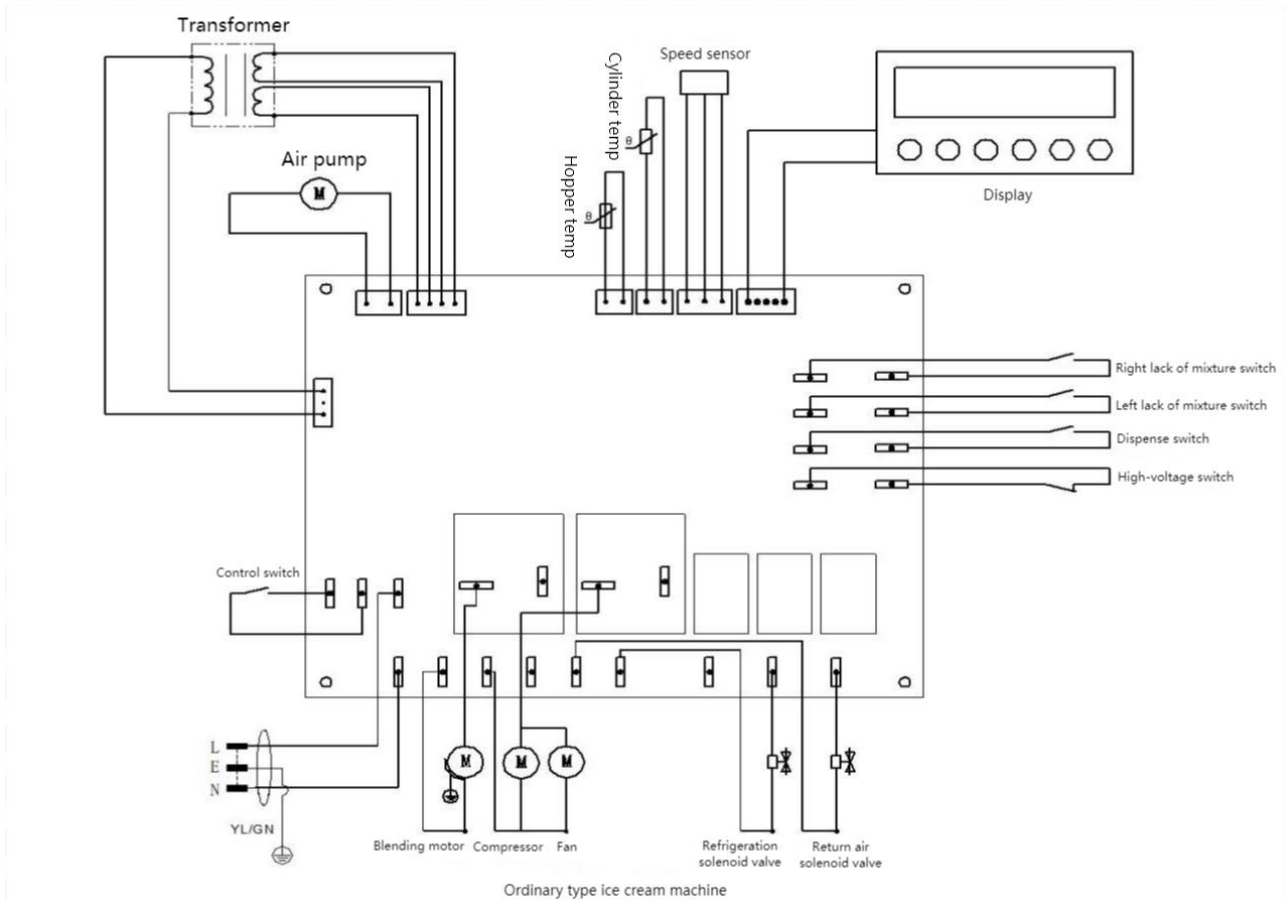

2: Singlre compressor with pre-cooling

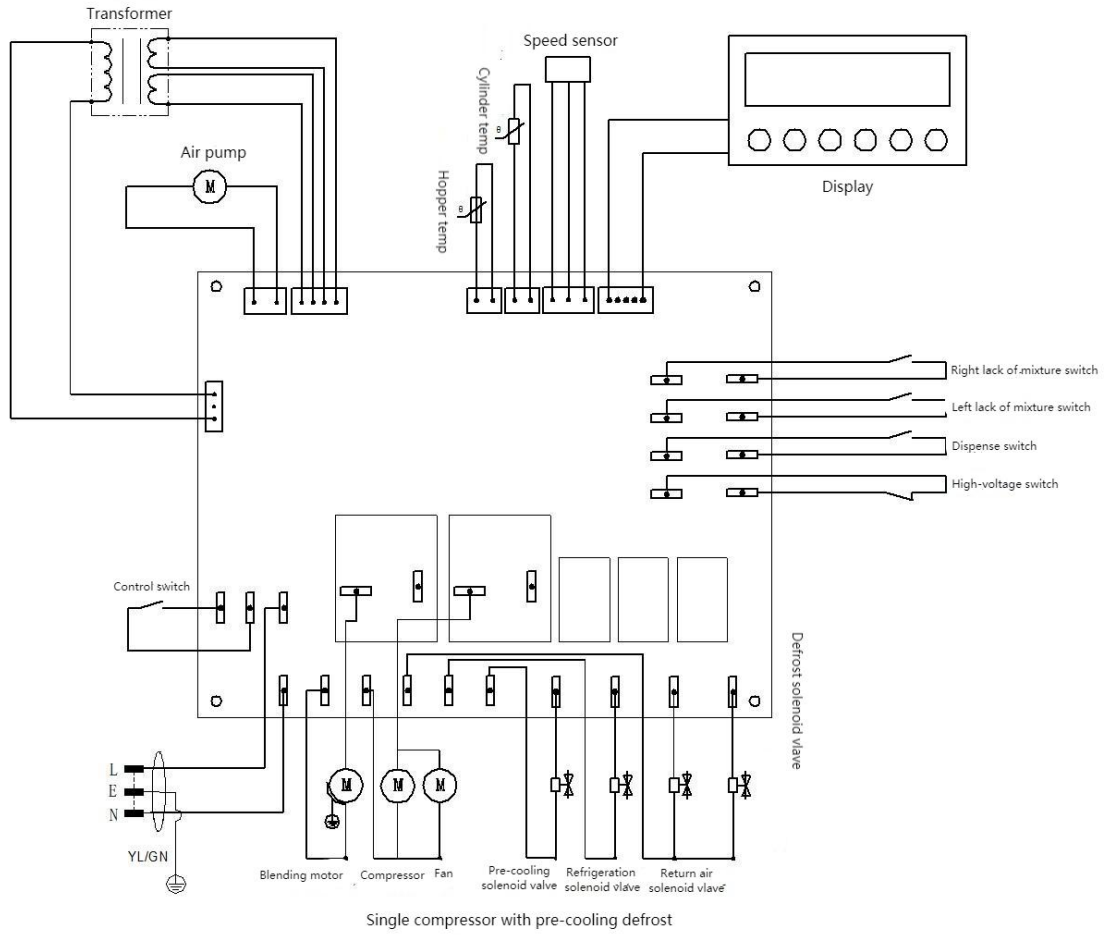

3: Double compressor with pre-cooling

