



IFT 65

LIST OF EXPLODED VIEWS



SHELL ASSY

COOLING SYSTEM

HYDRAULIC CIRCUIT

EVAPORATOR SUPPORT from s/n. 497147

EVAPORATOR SUPPORT till s/n. 497146

ELECTRIC PARTS

Rev. 9 - 08/06/2015



IFT 65

SHELL ASSY

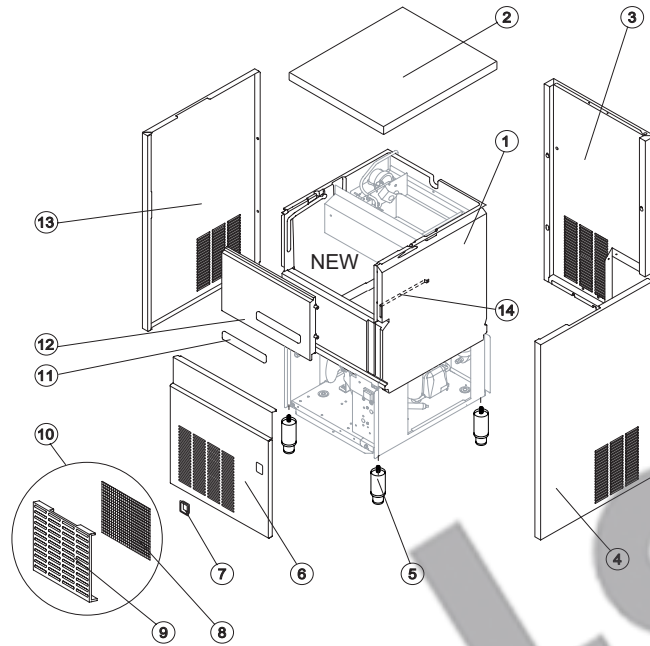

New version

Ref.	Spare Description	Code
1	Foamed Basin	NC11136
2	Top Assembly	NC221375
3	Grey Rear Side Panel	NC21383GR
4	Right Side Panel	N221416
5	Foot	N10557
6	Front Panel	NC221481
7	On-Off switch Frame	N10696
8	Filter	N18243
9	Grid	N10697
10	Grid Assembly	NC10697
11	Resinated Logo	N241330
12	Door Assembly	NC10360
13	Left Side Panel	N221415
14	Bulbe-Holder Pipe	N20521

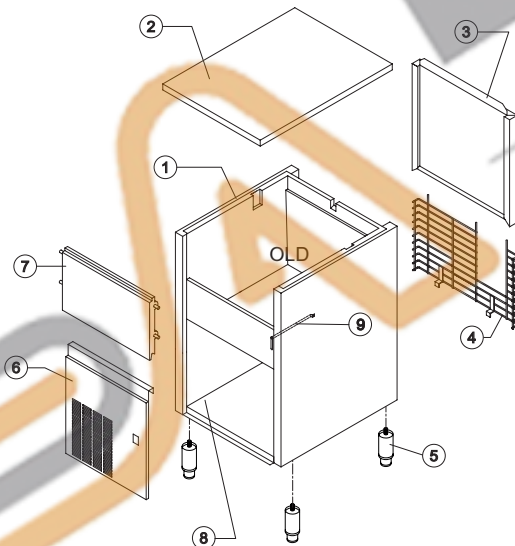

Old version

Ref.	Spare Description	Code
1	Foamed Cabinet Assy	NC11142
2	Top Assembly	NC22131
3	Rear Panel Assembly	NC21182
4	Rear Grid	ND12006
5	Foot	N20613
6	Front Grid Panel	N22544
9	Door Assy	NC10360
10	Base Plate	N21279
11	Bulb-holder Pipe	Current Version N20521
11	Bulbe-holder Pipe	Till s/n. 497146 N20522

Rev. 9 - 08/06/2015



Rev. 9 - 08/06/2015

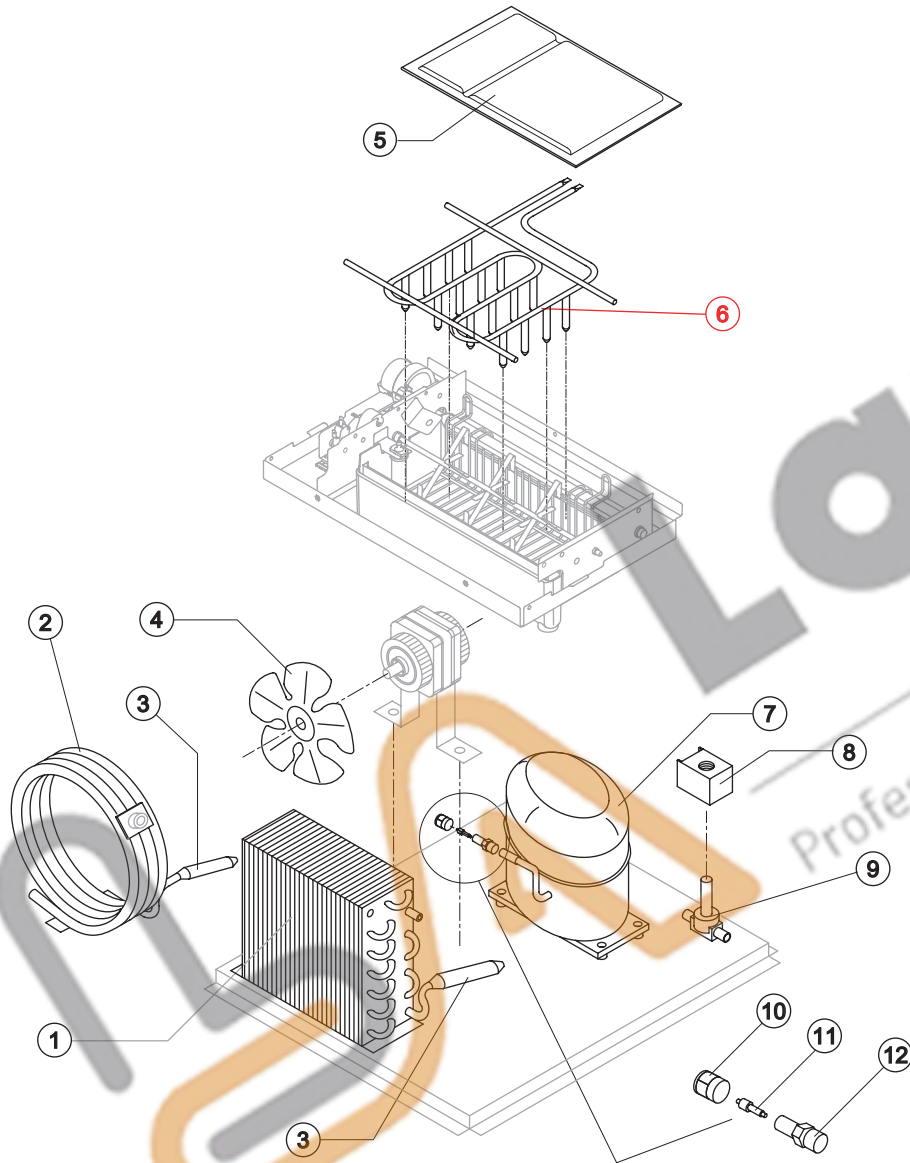

Common Parts

Ref.	Spare Description	Code
3*	Molecular Drier	N14009
5	Evaporator Cover Panel	N10487
6	Evaporator	Current Version ND14689
6	Evaporator	Till s/n. 497146 ND14525
7	Compressor	See Table -
8*	Hot Gas Valve Coil	N23091
9*	Hot Gas Valve Body	N20410
10*	Vacuum-Charge Valve Plug	N14006
11*	Vacuum-Charge Valve Device	N14005
12	Vacuum-Charge Valve Body	N14007

Parts for Air-Cooled Version Only

Ref.	Spare Description	Code
1	Air Condenser	N20283
4	Sucking Fan	N20095

Parts for Water-Cooled Version Only

Ref.	Spare Description	Code
2	Water Condenser	N14057

Rif. 7 - Compressor

Tension	Code
220/240V 50 Hz	N23886
220/230V 60 Hz	N23494A

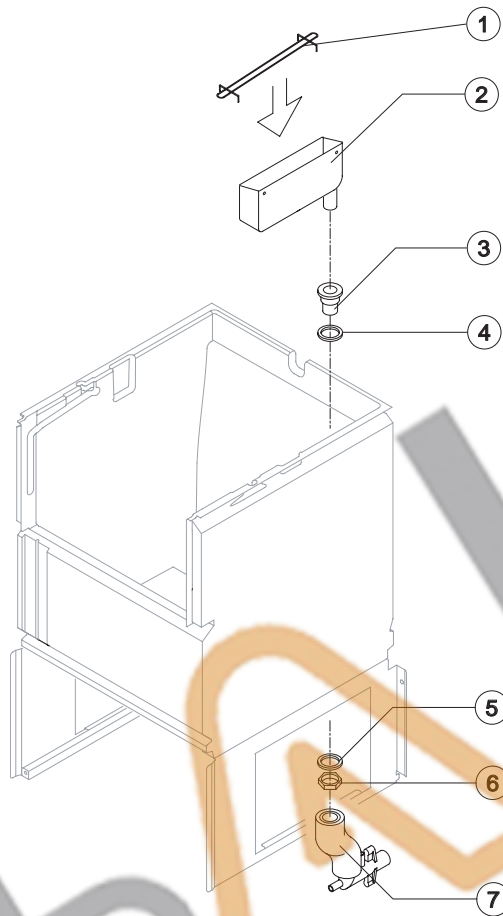

Common Parts

Ref.	Spare Description	Code
1	Water Collecting Basin Slide	N12072
2	Water Collecting Basin	N10456
3*	Water Collecting Basin Drain Pipe	N13158
4	Water Outlet Nipple	N10472
5	Silicone Gasket	N13006
6	Semirigid Polyethylene Gasket	N13007
7	Bin Discharge Nut	N10096

Parts for Air-Cooled Version Only

Ref.	Spare Description	Code
8	Discharges Manifold	NC10006

Parts for Water-Cooled Version Only

Ref.	Spare Description	Code
8	Discharges Manifold	NC26452



IFT 65

EVAPORATOR SUPPORT *New Version* from s/n. 497147

Rev. 9 - 08/06/2015

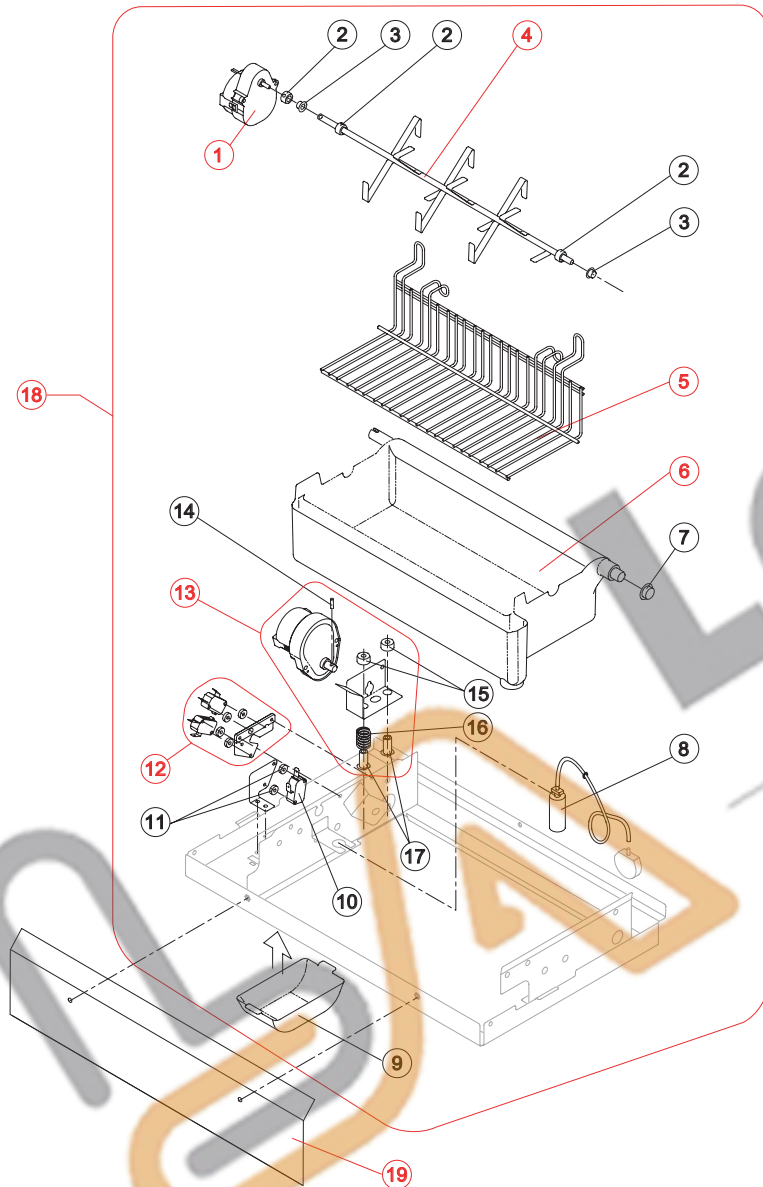

Ref.	Spare Description	Code
1*	Gearmotor (Paddles)	N23937
2	Shaft Stop Ring	N20227
3	Self-Lubricating Bush 06/06	N20230
4*	Shaft with Paddles	N20966
5	Internal Slide Bin	N12086
6*	Water Basin with Pivot	NC10589
7	Self-Lubricating Bush 12/07	N20231
8*	Air Trap with Pipe	NC10537
9	Gearmotor (Paddles) Protection	N10483
10*	Microswitch (Paddles - NO)	N23804
11	Switch Shimming Ring	N10250
12*	2 Microswitches (Basin - NC) Support Assembly	NC26747
13*	Gearmotor (Turnover Basin) with support Assy	NC26746
14	Shaft Pin for Gearmotor (Turnover Basin)	N20814
15	Special Ring	N20808
16	Spring (Gearmotor Support)	N20809
17	Threaded Pivot	N20807
18	Evaporator Support Plate Assembly	NC221175
19	Front Basin Cover	N221204



IFT 65

EVAPORATOR SUPPORT *Old Version* till s/n. 497146

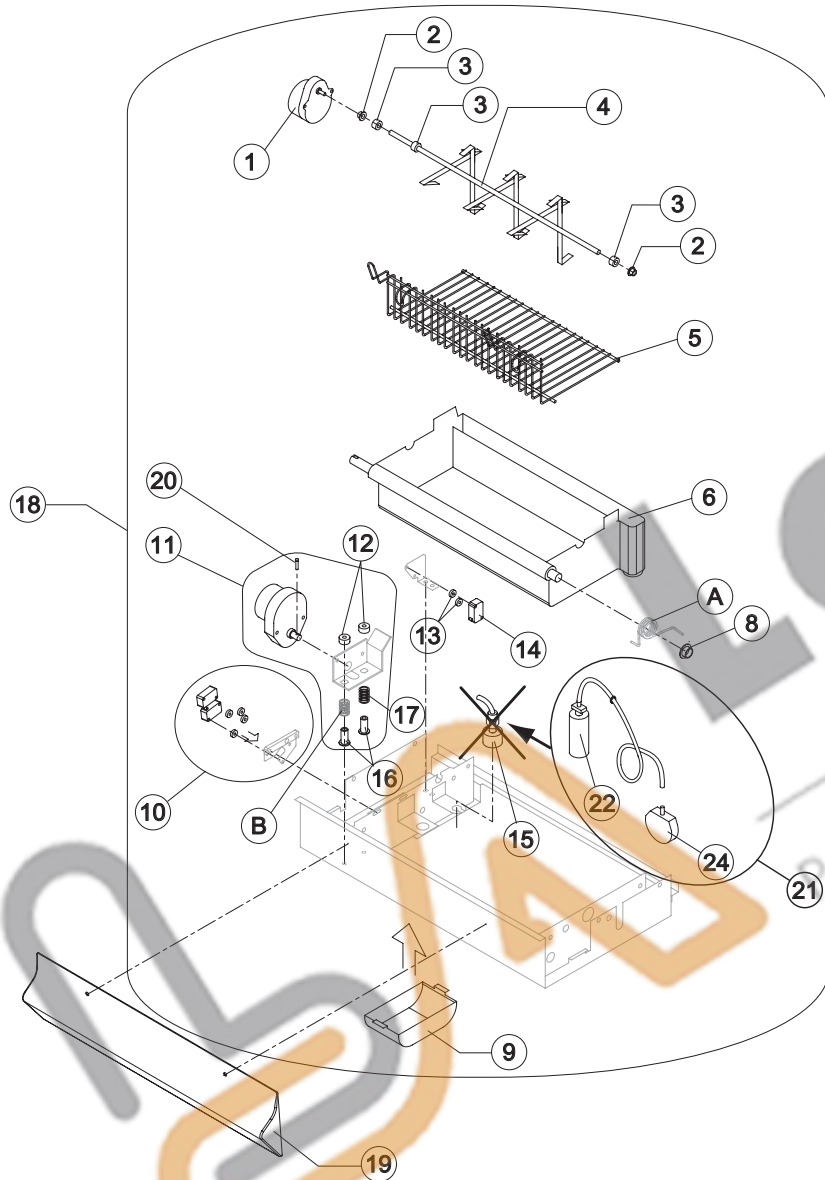

Ref.	Spare Description	Code
1	Gearmotor (Paddles)	N23802
2	Self-Lubricating Bush 06/06	N20230
3	Shaft Stop Ring	N20227
4	Shaft with Paddles	N20818
5	Internal Basin Slide	N12074
6	Water Basin with Pivot	NC10489
8	Self-Lubricating Bush 12/07	N20231
9	Gearmotor (Paddles) Protection	N10483
10	2 Microswitches (Basin - NC) Support Assembly	NC23803
11	Gearmotor (Turnover Basin) with Support assy	NC26742
12	Special Ring	N20808
13	Switch Shimming Ring	N10250
14	Microswitch (Paddles - NO)	N23804
15	Electromagnetic Level Switch	replaced by ref. 21
16	Threaded Pivot	N20807
17	Spring (Gearmotor Support)	N20809
18	Evaporator Support Plate Assembly	NC22141
19	Basin Protection	N10509
20	Shaft Pin for Gearmotor (Turnover Basin)	N20814
21	Water Level Pressure Switch Assy	NKIT23870
22	Air Trap with Pipe	NC10537
24	Water Level Pressure Switch	N23870



Eliminated the Lightning Spring ref. A and one Gearmotor Support Spring ref. B, suggested removal even from the models where they are present.



IFT 65

ELECTRIC PARTS

Common Parts

Ref.	Spare Description	Code
1*	Capacitor 0,068μF	NC23798
4	Anti Radio Interference Filter	NC23458
5*	Condenser Pressure Switch	N23175
6*	Bin Thermostat	NR23005
8*	Relay	N23190
9*	Green Light Switch(On-Off)	N23327
12*	Water Level Pressure Switch	N23870

Parts for Air-Cooled Version Only

Ref.	Spare Description	Code
3*	1 Way- Water Inlet Valve	N23220
7	Anti Radio Interference Filter	NC23459
11*	Fan Motor	N23029

Parts for Water-Cooled Version Only

Ref.	Spare Description	Code
2*	2 Ways- Water Inlet Valve	N23501
7	Anti Radio Interference Filter	NC23457
10*	Safety Thermostat Switch	NC23114

