



CM 650

LIST OF THE EXPLODED VIEWS

3rd Version

From s/n.213748 up Today



SHELL ASSY

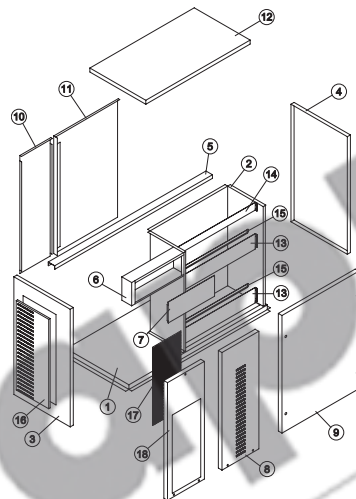

COOLING SYSTEM

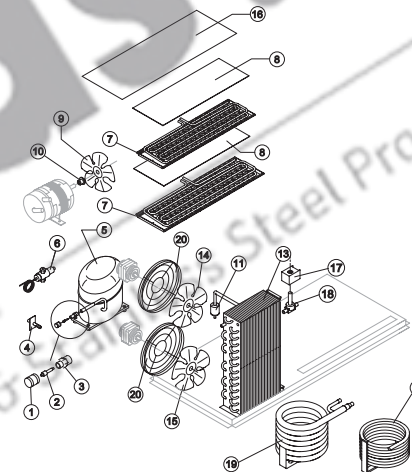

HYDRAULIC CIRCUIT

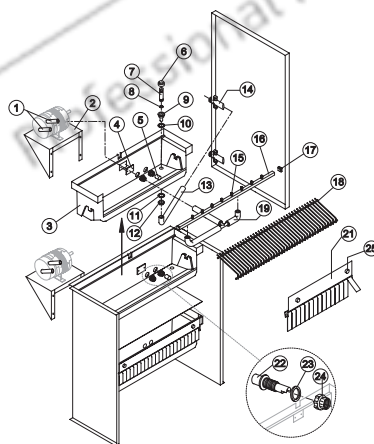

ELECTRIC PARTS

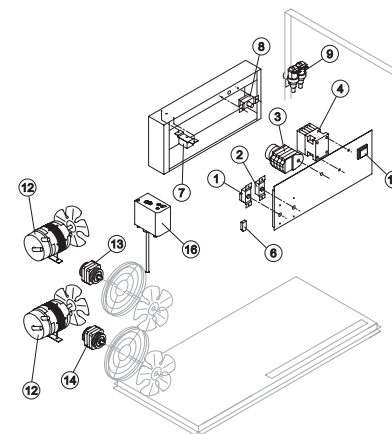

Rev. 12 - 16/01/2015



CM 650

3rd Version From s/n.213748 up Today

SHELL ASSY

Rev. 12 - 16/01/2015

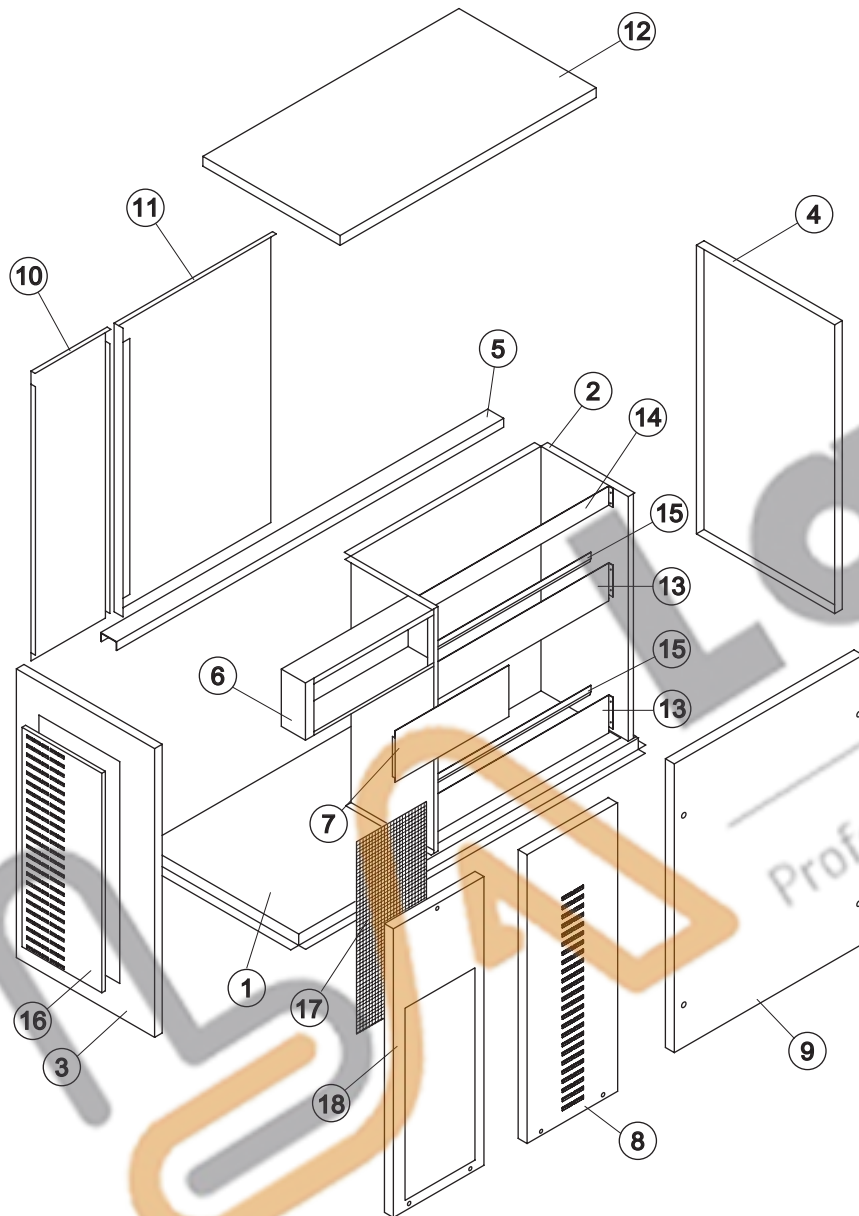

Ref.	Spare Description	Code
1	Base Plate	N21240
2	Evaporator Chamber	N22889
3	Left Side Panel	N22736
4	Right Side Panel	N22735
5	Cross Bar	N22838
6	Electrical Box	N22837
7	Electrical Parts Plate	N21239
9	Front Panel (Bin Side)	NC22744
10	Rear Panel (Group Side)	N21288
11	Rear Panel (Bin Side)	N21241
12	Top Assy	N22738
13	Bulkhead	N22890
14	Upper Bulkhead	N22809
15	Inner Basin Reinforcement	N22740
16	Left Side Panel	N22810

Parts for Air-Cooled Version Only

Ref.	Spare Description	Code
17*	Filter	N18178
18	Fron Panel (Group Side)	N22986

Parts for Water-Cooled Version Only

Ref.	Spare Description	Code
8	Fron Panel (Group Side)	N22741



CM 650

3rd Version From s/n.213748 up Today

COOLING SYSTEM

Common Parts

Ref.	Spare Description	Code
1*	Vacuum-Charge Valve Plug	N14006
2*	Vacuum-Charge Valve Device	N14005
3	Vacuum-Charge Valve Body	N14007
5	Compressor	See Table
7	Evaporator	See Table
8	Evaporator Cover Panel	N10058
9	Sucking Fan	N10213
10	Fan Fixing Hub	N10014
11*	Solid Core Drier	N14084
16	Upper Evaporator Cover Panel	N10439
17*	Hot Gas Valve Coil	N23091
18*	Hot Gas Valve Body	N20409

Parts for Air-Cooled Version Only

Ref.	Spare Description	Code
13	Air Condenser	N20406
14	Sucking Fan 275 / 34°	N20153
15	Sucking Fan 275 / 34°	N20153
20	Fan Guard	N12054

Parts for Water-Cooled Version Only

Ref.	Spare Description	Code
4	Rubber Holder with Plate	Current Version N20938
4	Rubber Holder with Plate	Till s/n. 459880 NC20462
6	Pressostatic Valve	N20149
12	Water Condenser	Till s/n. 537714 N14617
19	Water Condenser	Current Version N14660

Ref. 5 - Compressor

Voltage	Code	Code
	Current Version	Till s/n. 661502
T11	N231079	N23647
T12	N231081	N23651
T14	N231083	N23708
T15	N231085	N23709
T16	N231083	N23708

Ref. 7 - Evaporator

Kind of Cube	Code
18 g. (Standard)	ND10214
33 g.	ND10092
13 g.	ND10126
42 g.	ND10477
60 g.	ND10555

Rev. 12 - 16/01/2015

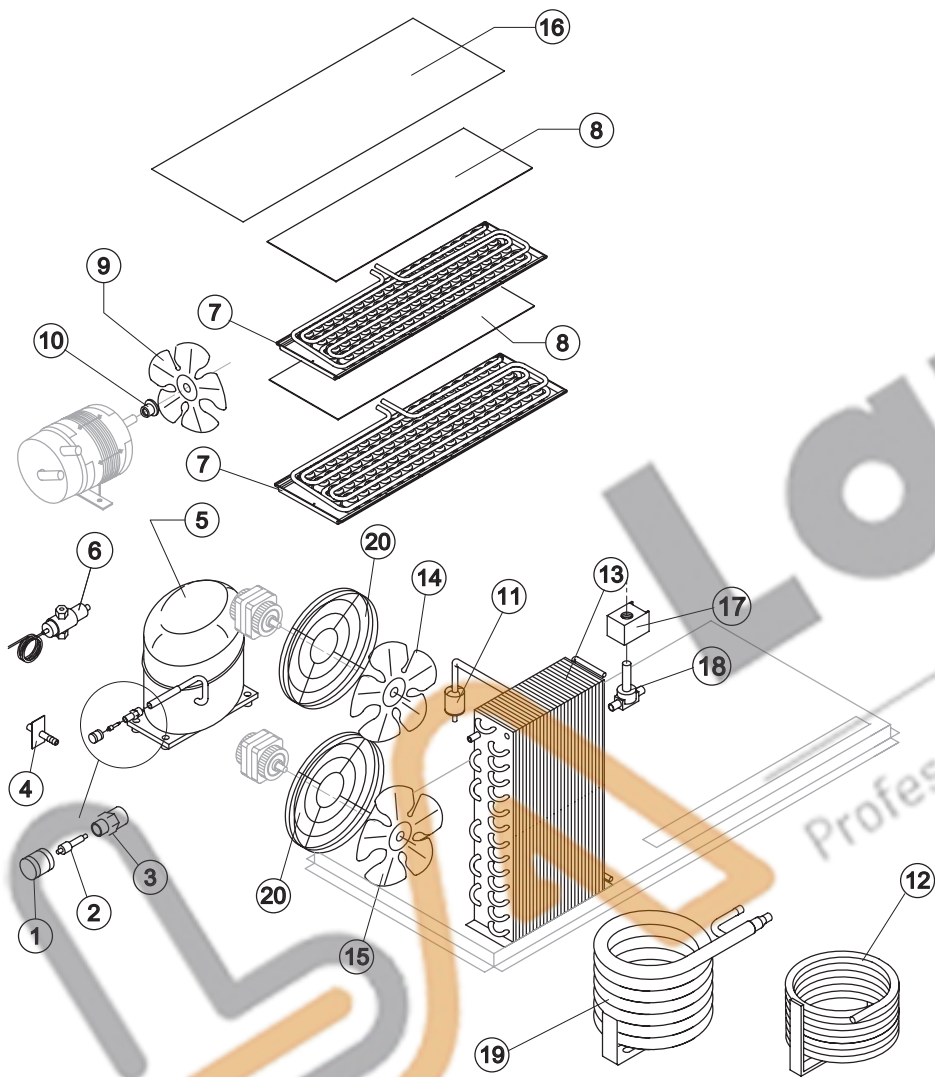



CM 650

3rd Version From s/n.213748 up Today

HYDRAULIC CIRCUIT

Common Parts

Ref.	Spare Description	Code
1	Pump Suction/Delivery Pipe	N13150
2	Pump Support Plate	N221611
3	Inner Basin	N10440
4	Slide Keep Plate	Till s/n. 233485 N10009
5*	Pump Suction Filter	N20005
6	Overflow Cap	Till s/n. 243833 N10305
7*	Overflow Pipe	N10133
8*	OR Gasket for Overflow Pipe	N20233
9	Water Outlet Nipple	N10471
10	Silicone Gasket	N13006
11	Semirigid Polyethylene Gasket	N13007
12	Bin Discharge Nut	N10096
13	Water Discharge Pipe	N13054
14	Discharges Manifold	NC10415
15	Sprayer	ND20002
16*	Sprayers Bar Assembly	See Table -
17	Sprayers Bar Plug	N10012
18	Ice Cubes Slide	See Table -
19	Sprayers Bar Pipe Connection	NC13036
21	Flags Support Assy	NC22134
22	Fitting of the Pump Suction/Delivery Pipes	N10424
23	Gasket for Pump Suction/Delivery Pipes	N13143
24	Fittings Locking Ring	N10405
25	Fixing Screw	N20009

Ref. 16* - Sprayers Bar Ass.

Kind of Cube	Code
18 g. (Standard)	NC20144
33 g.	NC20157
13 g.	NC20200
42 g.	NC20157
60 g.	NC20941

Ref. 18 - Ice Cube Slide

Kind of Cube	Code
18 g. (Standard)	ND12022
33 g.	ND12033
13 g.	ND12040
42 g.	ND12033
60 g.	ND12084

Rev. 12 - 16/01/2015

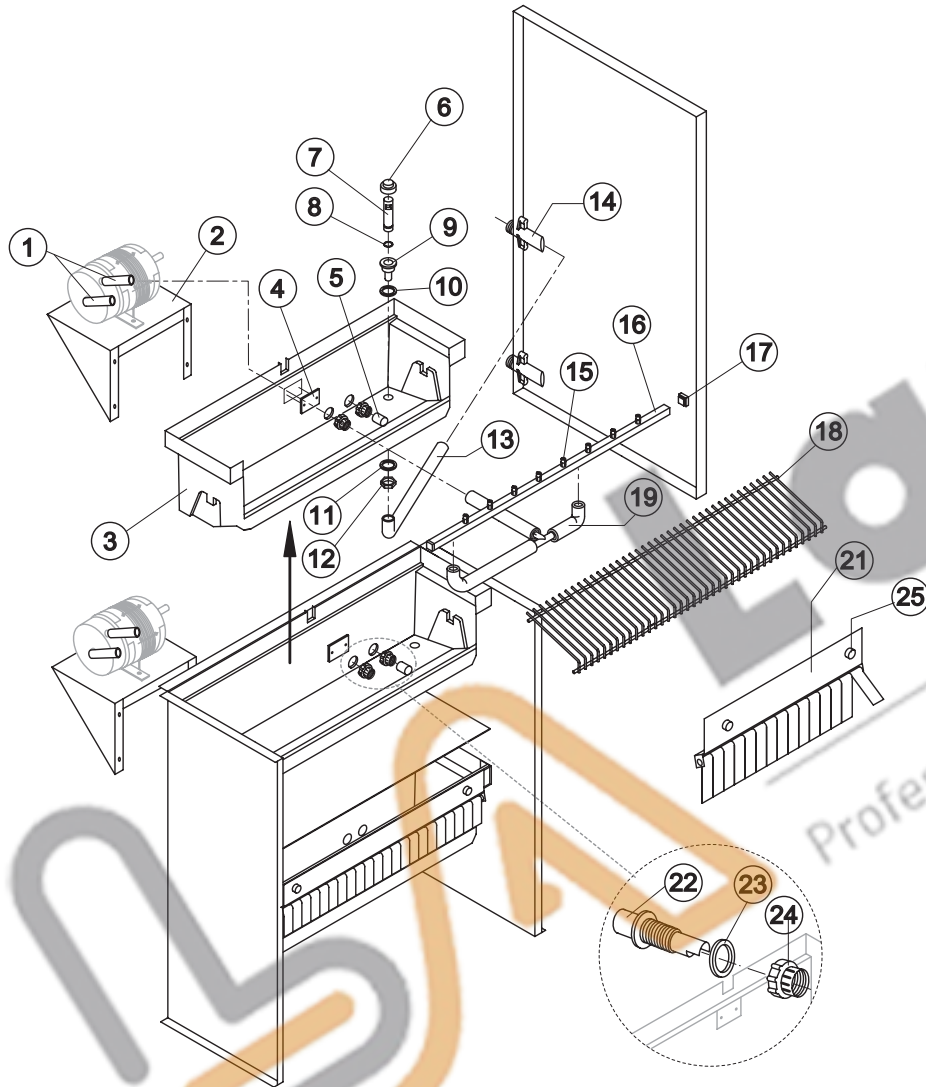



CM 650

3rd Version From s/n.213748 up Today

ELECTRIC PARTS

Common Parts

Ref.	Spare Description	Code
1*	Bin Thermostat	NR23421
2*	Evaporator Thermostat	NR23591
3*	Timer	See Table
4*	Contactor	N23147
8	Safety Pressure Switch	N23342
9*	2 Ways- Water Inlet Valve	N23157
12*	Pump Assy	NC23691
15*	On/Off Rocker Switch	N23327
16	Low pressure safety switch	N23763

Parts for Air-Cooled Version Only

Ref.	Spare Description	Code
6	Anti Radio Interference Filter	Only T11, T14, T15 NC23459
7*	Condenser Pressure Switch	See Table
13	Fan Motor	N23121
14	Fan Motor	N23121

Ref. 3* - Timer

Voltage	18g Cube	33g Cube	13g Cube	42g Cube	60g Cube
T11	N23247	N23248	N23472	N23780	N23922
T12	N231082	N231080	N231077	N231080	TBD
T14	N23247	N23248	N23472	N23780	TBD
T15	N23247	N23248	N23472	N23780	N23922
T16	N231082	N231080	N231077	N231080	TDB

Ref. 4* - Contactor

Voltage	Code
T11	N23147
T12	N23963
T14	N23147
T15	N23147
T16	N23963

Ref. 7* - Cond. Pressure Switch

Voltage	Code
T11	N23175
T12	N23175
T14	N23175
T15	N23175
T16	N23175

Ref. 9* - 2 Ways- Water Inlet Valve

Voltage	18/13g Cube	33g Cube	42g Cube	60g Cube
T11	N23157	N23784	N23784	N23784
T12	N23157	N23784	N23784	N23784
T14	N23157	N23784	N23784	N23784
T15	N23157	N23784	N23784	N23784
T16	N23157	N23784	N23784	N23784

Rev. 12 - 16/01/2015

